

(No Model.)

L. J. BAKER.

Machine for Grinding Knives, &c.

No. 238,549.

Patented March 8, 1881.

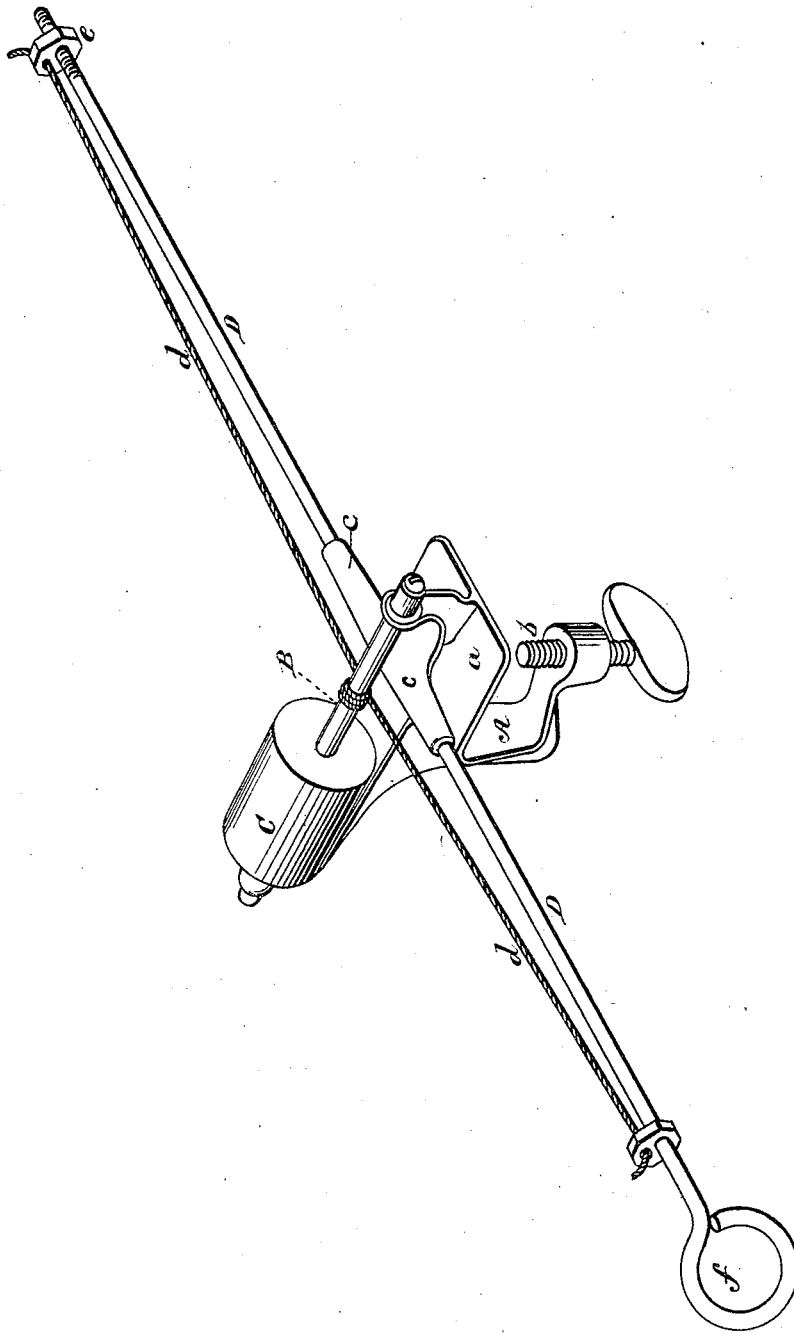

Witnesses.
H. L. Clark
Charles J. Proctor

Inventor.
L. J. Baker.
F. Curtis. Atty.

UNITED STATES PATENT OFFICE.

LORING J. BAKER, OF BOSTON, MASSACHUSETTS.

MACHINE FOR GRINDING KNIVES, &c.

SPECIFICATION forming part of Letters Patent No. 238,549, dated March 8, 1881.

Application filed November 29, 1880. (No model.)

To all whom it may concern:

Be it known that I, LORING J. BAKER, a citizen of the United States, residing at Boston, in the county of Suffolk and State of Massachusetts, have invented certain new and useful Improvements in Machines for Grinding Knives, &c.; and I do hereby declare the following to be a full, clear, and exact description of the invention, such as will enable others skilled in the art to which it appertains to make and use the same, reference being had to the accompanying drawings, and to letters or figures of reference marked thereon, which form a part of this specification.

The subject of this invention and application is a machine or implement for grinding or sharpening knives, scissors, drills, or other instruments or tools; and it consists in a circular or cylindrical stone or wheel secured to a shaft mounted in a standard or head-stock, containing provision for being secured to a table or bench, and the combination, with such stone or wheel and its support, of a rod or bar adapted to slide in bearings in the head-stock, and engaging the shaft, by means of a bow-string, rack and pinion, or otherwise, in such manner that as the slide-rod is moved backward and forward by the hand of the operator in a plane at right angles to the axis of the shaft and wheel it imparts alternating rotary motions to the wheel in directions the reverse of those of the rod, the whole being so arranged that the wheel may be driven by one hand of the operator and the blade of the instrument to be sharpened held upon the periphery of the wheel with the other hand; or, by means of an eye or handle upon the rod, the wheel may be rotated and the instrument held against it by one and the same hand, if desired.

The drawing accompanying this specification represents an isometric elevation of a machine or implement embodying my invention.

In this drawing, A represents a standard or support resembling the head-stock of a turning-lathe, and provided at its lower part with a shelf, *a*, and clamp-screw *b*, by which it may be secured in an upright position to a table or bench, a horizontal shaft, B, being mounted in the said head-stock, in further resemblance to the arbor of a lathe, and a circular or cylindrical

grinding stone or wheel, C, being secured to the shaft in a manner corresponding to the pulley usually secured to such arbor. The stone or wheel C may be composed of natural or artificial stone, emery, vulcanite, or other material which shall adapt it to the purpose of grinding or sharpening knives, scissors, drills, or other instruments or tools.

D in the accompanying drawing represents a straight rod or bar, supported within a tubular guide or box, *c*, erected upon or secured to the head-stock below the shaft, the rod being disposed at right angles to the axis of such shaft and of the grinding-wheel, and adapted to slide backward and forward in its bearing. The purpose of the slide rod or bar D is to impart rotary motions in opposite directions to the grinding-wheel, and this may be effected in various ways. As shown in the accompanying drawing, a "bow-string," *d*, is employed, secured at its opposite ends to the ends of the slide-bar and wound about the shaft B; or a toothed rack may be cut upon the upper edge of the slide-bar D, to engage a pinion secured to the shaft, and engaging said rack through a proper opening in the guide *c*; or, in lieu of the foregoing instrumentalities, other known intermediaries between the rod and the shaft can be used, which, when actuated by the reciprocal movement of the rod, will impart a rotary movement to the shaft. One end of the bow-string may be secured to a nut, *e*, screwed upon the end of the slide-bar, by which means the slack of the string may be taken up.

To enable the slide-bar D to be readily moved backward and forward, I form upon its front end an eye or handle, *f*. By inserting the little finger of the right hand in the said eye *f* and grasping the handle of the article to be ground in the same hand, the wheel may be put in motion and the article held upon it with one and the same hand, if desired.

It will be seen that reciprocating rectilinear motions of the slide-bar impart corresponding alternating rotary movements to the grinding-wheel at greatly-accelerated speed, and that the periphery of the wheel travels in an opposite direction to that of the slide bar or rod. Consequently the wheel rotates in a direction contrary to that taken by the instrument or tool

held against the upper edge of such wheel and moving by and with the slide-bar in the act of sharpening said instrument.

I claim—

5 The combination, with the head-stock, the shaft mounted in bearings therein, and the grindstone or wheel fixed on said shaft, of the slide-bar mounted in bearings in said head-stock and the bow-string or its equivalent at-
10 tached to and carried by said bar, and engag-
ing said shaft, substantially as hereinbefore set

forth, whereby the reciprocating movement of the slide-bar imparts, through the intermediary of the bow-string or its equivalent, rotary movement alternately in opposite directions to the 15 grinding-wheel shaft.

In testimony whereof I hereto affix my signature in presence of two witnesses.

LORING J. BAKER.

Witnesses:

F. CURTIS,

S. L. CLARK.